

No.	REVISION/ISSUE	DATE

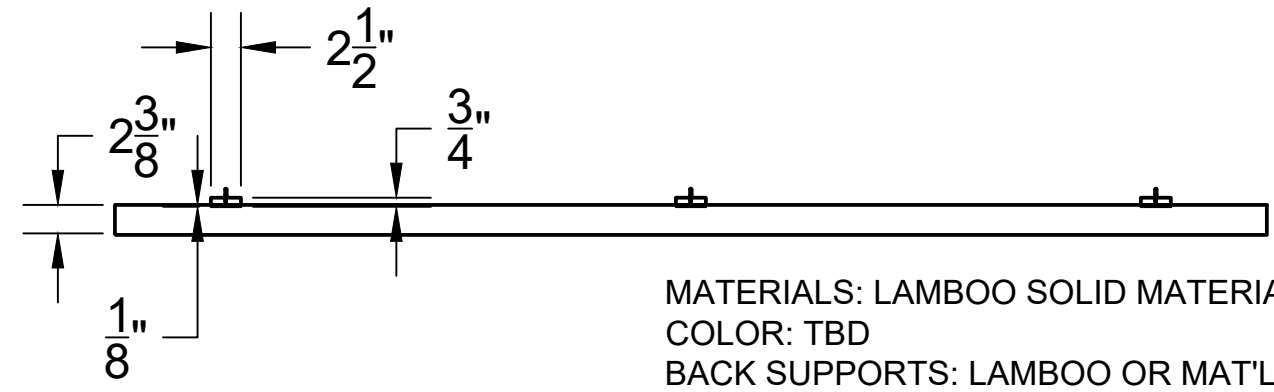
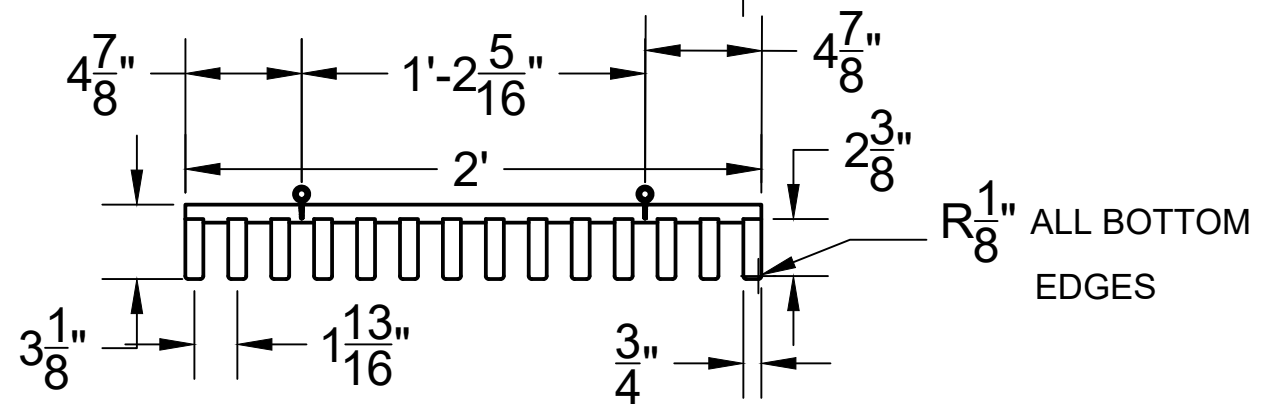
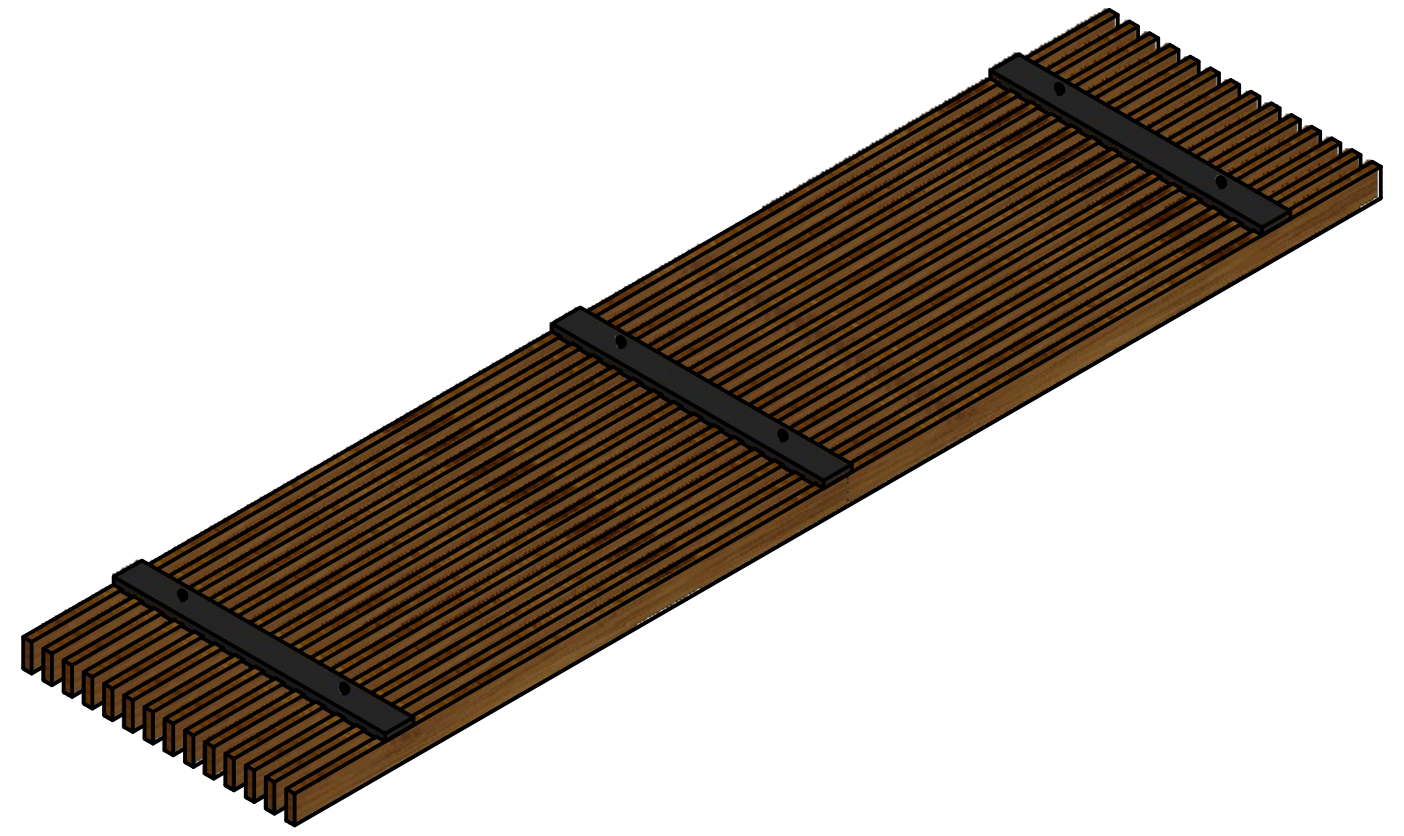
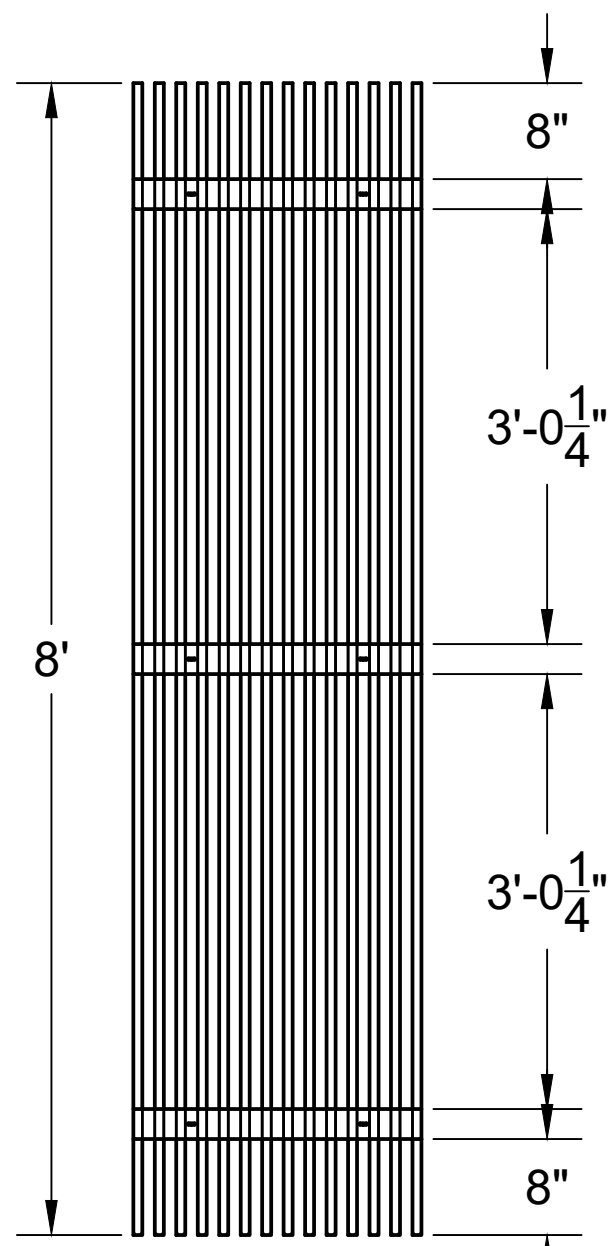

MATERIALS: LAMBOO SOLID MATERIAL  
 COLOR: TBD  
 BACK SUPPORTS: LAMBOO OR MAT'L EQUIVALENT  
 GRILLE PIECES: CAN BE CUSTOMIZED PER PROJECT  
 HANGING HARDWARE PROVIDED BY INSTALLER  
 EST. WEIGHT PER SQFT: 4.125 LBS/SQFT

BY SIGNING THIS DOCUMENT YOU THE CUSTOMER HAVE AGREED TO THE INFORMATION AS STATED IN THIS DOCUMENT.  
 ANY CORRECTIONS REQUESTED AFTER DRAWINGS HAVE BEEN APPROVED WILL BE CHARGED BY LAMBOO ON AN HOURLY  
 BASIS. SIGNATURE: \_\_\_\_\_

**TITLE:**  
 LAMBOO® SKYLINE™ 3" CEILING GRILLE - 2' x 8'

DRAWN BY:  
 JDH  
 DATE:  
 03/17/2025  
 SCALE:  
 NTS

SHEET  
**1**



301 W. EDWARDS STREET/LITCHFIELD, IL 62056 P:866-966-2999 E:SALES@LAMBOO.US W: WWW.LAMBOO.US  
 DISCLAIMER:  
 ALL INFORMATION CONTAINED WITHIN THIS DOCUMENT IS SOLE PROPERTY OF LAMBOO TECHNOLOGIES, LLC. ANY REPRODUCTION IN PART OR AS A WHOLE WITHOUT THE WRITTEN PERMISSION  
 OF LAMBOO TECHNOLOGIES, LLC IS STRICTLY PROHIBITED.